

# VTLG6S

H 300 mm  
D 380 mm  
L 1320 mm

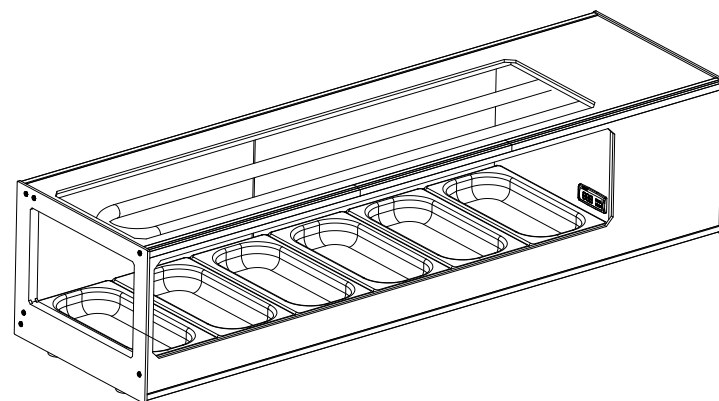

## 3D



## GENERAL SIZES

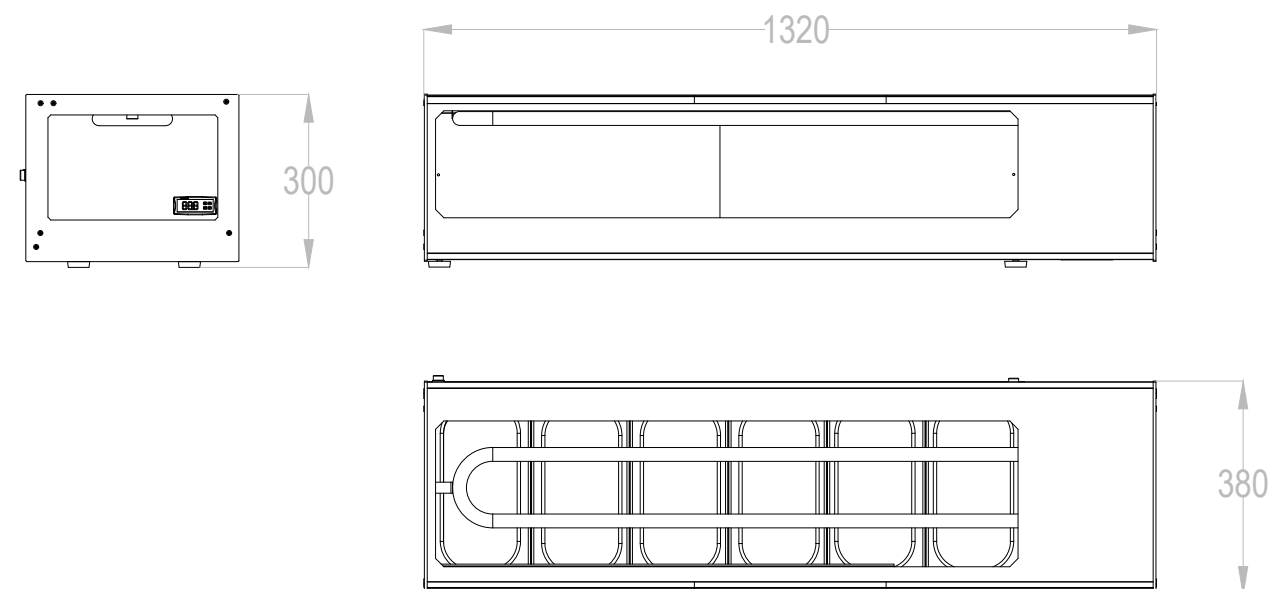

## TECHNICAL DATA

### Installation

Plug-in

### Temperature

+0 / +4°C

### Refrigerant

R600A

### Refrigeration

Ventilated

### Compressor

HXD55

### Defrost

Automatic

### Climate class

3

### Glass type

Single glass

### Opening system

Rear sliding double door

### Lighting

Double LED 4000K

### Configuration

-Mechanical control panel

### External dimensions (LxDxH)

1320 x 380 x 300 mm

### Capacity (gross/net)

75,6 / 25 L

### Weight

65 KG

### Energy class

C

### Energy efficiency index

25,6

### Annual energy consumption

1611,84 kWh/A

### Operating conditions

25°C / 60% RH

### Frigorific input

170W

### Electrical input

85W

### Power supply

230V / 50Hz

### Openings (Rear/Front)

Yes / No

## GOOD PRACTICES

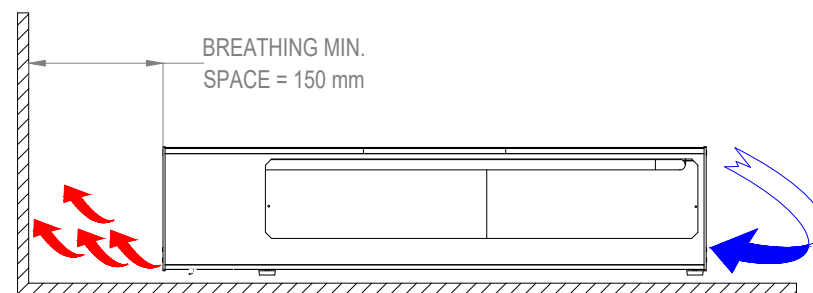

## ELECTRIC DIAGRAM

